



**CARRON CAST IRON STOVE
INSTALLATION AND OPERATING INSTRUCTIONS**



**Carron stoves are imported and distributed in the UK by:
JIG UK Ltd, Hurlingham Business Park, Fulbeck Heath,
Grantham, Lincolnshire, NG32 3HL**

email: sales@carron.uk.net freephone: 0808 129 2224

www.carron.uk.net

**A qualified solid fuel engineer must carry out the installation of this stove.
We cannot accept responsibility for products not installed in this way.
All local regulations, including those referring to national and European
Standards need to be complied with when installing the appliance.
A list of qualified engineers is available from: www.hetas.co.uk**

Technical Data	Wood	Smokeless fuel
Output	7.3 kW	6.6 kW
Efficiency	79.3 %	71.5 %
CO at 13% O ₂	0.33 %	0.31 %
Flue temperature	309 °C	279 °C
Flue draught	12 Pa	12 Pa
Flue gas mass flow	5.0 g/s	7.4 g/s
Weight of Stove	89.4 Kg	55.0 Kg

CE
JIG UK Ltd Hurlingham Business Park Fulbeck Heath Grantham Lincolnshire NG32 3HL 07
EN13240:2001 THE CARRON STOVE Minimum distance to combustible materials: Behind the stove: 400mm To the side of the stove: 500mm
CO at 13% O ₂ : 0.33% Flue gas temperature: 309°C Efficiency: 79.3% Nominal Output: 7.3kW Fuel Type: Wood
CO at 13% O ₂ : 0.31% Flue gas temperature: 279°C Efficiency: 71.5% Nominal Output: 6.6kW Fuel Type: Smokeless fuel

Replacement parts list

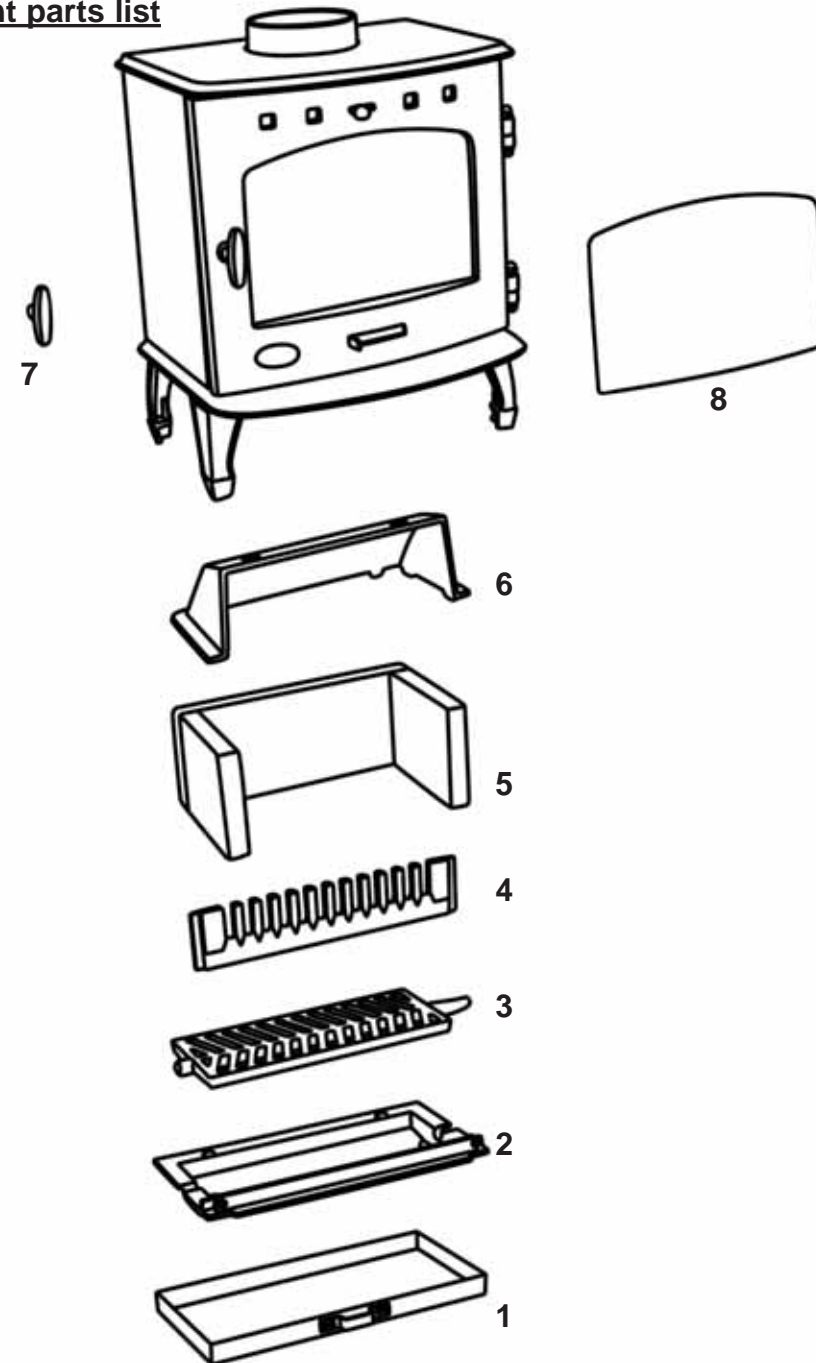

Flue Connection

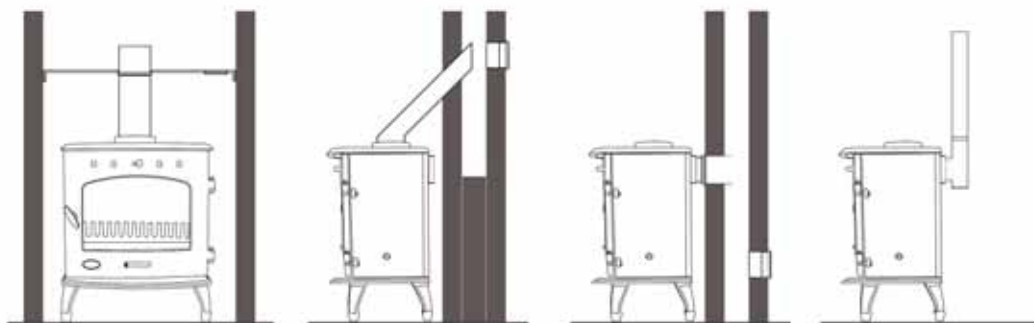

Attach the flue outlet to the stove with the screws and nuts provided. Use a steel closure. Attach the flue outlet to the stove with the screws and nuts provided. Use a steel closure plate to seal off the chimney; a cleaning door must be fitted into the plate or flue, and a steel sealing collar must be used to fit the flue into the steel plate. Seal all joints with fire cement.

- 1. Ashpan (BHC082)
- 2. Grate frame (BHC077)
- 3. Grate (BHC076)

- 4. Front firebar (BHC075)
- 5. Firebrick set (BHC081)
- 6. Baffle plate (BHC074)

- 7. Handle (BHC002)
- 8. Glass (BHC080)

Installation instructions

Ensure that the floor has sufficient load bearing capacity.
Fit a load bearing plate if necessary.

To ensure that your chimney meets the required specifications it must: -

- be at least 5 metres high
- have no bends sharper than 45 degrees
- be swept clear of any obstructions by a qualified chimney sweep
- terminate at least 1 metre above any roof ridge
- have an internal cross-section of between 0.018m² and 0.14m²
- be free from sources of leakage
- be connected only to the one appliance i.e. not a shared flue system
- be well insulated, or have a wall thickness of at least 100mm
- Attach the legs using the bolts supplied

Place the stove on a solid non-combustible hearth extending 300mm at the front of the stove, 150mm either side of the stove and 50mm at the rear. The hearth must have a thickness of at least 12mm. The maximum hearth temperature attained during testing was 83.2°C (Refer to document J of the UK Building Regulations)

Minimum Installation Clearances

	Side (mm)	Rear (mm)
Combustibles	400	500
Non Combustibles	150	100

Ensure there is a permanent air entry opening or openings with a total free area of at least 550mm² per kW of appliance rated output above 5kW, ie 2kw x 550 mm² =1100 mm².

When installing any air inlet grilles ensure they are positioned so they are not liable to blockage.

Note: The Stove must not be installed in a room with an extractor fan operating.

Operating Instructions

Fuels suitable for use in your Carron Stove: -

Wood – logs (**no larger than 250mm**) should be dried for at least a year prior to burning, for other fuels please contact the manufacturer. The stove is suitable for intermittent operation and we recommend a refuel time of 1 hour.

Smokeless Fuels

Fuels unsuitable for use in your Carron Stove: -

Petroleum Coke – this burns with an extremely high heat and its use will cause damage to the stove.

Household Waste – can produce dangerous fumes and should not be burnt in the stove. No liquid fuels to be used on this stove, please remember that this stove is not an incinerator.

Lighting the stove for Woodburning – please note that the first fire you light in your stove should be small, with the air inlet set as low as possible. This will prevent possible damage to the stove.

Place a small amount of screwed up paper and dry sticks, or several firelighters, at the back of the grate, and light them. Once they are burning, fill the stove with dry fuel and set the air control to as high as possible.

Do not fill the stove to a level higher than the bricks, and do not operate the stove with the door open, except during refuelling.

Controlling the stove - Setting the primary air supply (the inlet below the glass door) air control – sliding the air control to the right will allow the maximum amount of air into the stove, and cause the fire to burn quickly. Sliding it to the left will allow the minimum of air into the stove, and the fire will burn more slowly, and give off less heat. Setting the secondary air supply (the inlet above the glass door) air control – is the same operation as above. These air supplies must be kept clear of blockages and regularly checked.

If the stove goes out with fuel still in it, the air controls are set too low. Generally the ideal setting is to have the primary inlet almost closed and the secondary inlet 1/2 open. However this may vary depending on the flue draught and you will need to fine tune these settings to suit your preferred burn rate. Should the stove overheat, shut down the stove by ensuring the door and all inlets are closed.

Cleaning the stove – To ensure the performance of your stove is not affected, regular cleaning is necessary. To clean, allow the stove to cool, then wipe with a soft damp cloth. The throat plate should be removed and cleaned monthly along with checking the door seals for damage.

Do not use any abrasive cleaning products, as they will damage the finish of the stove.

The window is self-cleaning due to the “air-wash” at the top of the door. The use of damp fuels may cause staining of the window. After long periods of non-use it is necessary to check the flue for blockages.

Emptying ashes – ensure ashes are entirely cool before they come into contact with plastic dustbins or bin-bags. It is important that ash does not build up to the extent that it contacts the underside of the grate.

Precautions to note:

Carron stoves do not contain asbestos. However, please take care not to disturb any existing asbestos when removing an old stove.

The stove is very heavy; move it with assistance.

Take care to ensure fire cement does not come into contact with skin.

In the unlikely event of a chimney fire, close the stove door and both air supplies, evacuate the property immediately, and call the fire brigade. Do not attempt to extinguish your stove.

Persistent fume emission should not occur if the product is properly installed and operated. However, should this occur, take immediate action as follows:-

- ventilate the room
- extinguish the fire
- check the chimney/flue for blockages and clean if required

Seek expert advice if necessary.

The stove and flue pipe will become extremely hot during use; take care especially when children or the infirm are present. Do not store flammable materials near to the stove. Any combustible furnishings must be at least 500mm away.

Only use replacement parts supplied by the manufacturer and do not modify the stove in any way.

Warranty

Carron Stoves are supplied with a 3 year stove body and 1 year inner components warranty.

This warranty does not cover items considered consumables. These items include door glass, fire bricks, fire rope and grates. The use of incorrect fuels would invalidate this warranty.

This appliance must be installed by a HETAS engineer. Proof of purchase and certificate of installation would be required in the case of a warranty claim.

Occasionally the enamel finish can show a crazing/cracking effect on the surface of the stove during use. This effect will normally lessen as the stove cools and should not be considered a defect. This crazing effect can be made worse by incorrect fuel or over-fueling.